

PROGRAM FBUse

```

VAR
FB1 : BitToWorldFBD;
FB2 : BitToWorldST;
Result : ARRAY[ 0..1 ] OF WORD;
END_VAR

```

```

1 (* ***** *)
2 (* PROGRAM "FBUse" *)
3 (* ***** *)
4 (* In questoprogramma utilizzo le due FB. *)
5 (* ----- *)
6 (* Uso FB in FBD. *)
7
8     FB1.b00:=TRUE;
9     FB1.b08:=TRUE;
10    FB1();
11    Result[0]:=FB1.Out;
12
13 (* Uso FB in ST. *)
14
15    FB2.b00:=TRUE;
16    FB2.b08:=TRUE;
17    FB2();
18    Result[1]:=FB2.Out;
19
20 (* [End of file] *)
21
22

```

|                      |                 |
|----------------------|-----------------|
| Project : BitToWorld |                 |
| PROGRAM : FBUse      |                 |
| Release : NewFB      | Ver :1.00       |
| Author :             | Date:20/11/2013 |
| Note :               | Page:1 of 1     |

FUNCTION\_BLOCK BitToWordFBD

```

VAR_INPUT
b00 : BOOL;
b01 : BOOL;
b02 : BOOL;
b03 : BOOL;
b04 : BOOL;
b05 : BOOL;
b06 : BOOL;
b07 : BOOL;
b08 : BOOL;
b09 : BOOL;
b10 : BOOL;
b11 : BOOL;
b12 : BOOL;
b13 : BOOL;
b14 : BOOL;
b15 : BOOL;
END_VAR

```

```

VAR_OUTPUT
Out : WORD;
END_VAR

```

```

VAR
BLow : BitToByte;
BHigh : BitToByte;
ToWord : ByteToWord;
END_VAR

```

|  |                               |                 |
|--|-------------------------------|-----------------|
|  | Project : BitToWord           |                 |
|  | FUNCTION BLOCK : BitToWordFBD |                 |
|  | Release : NewFB               | Ver :1.00       |
|  | Author :                      | Date:20/11/2013 |
|  | Note :                        | Page:1 of 2     |

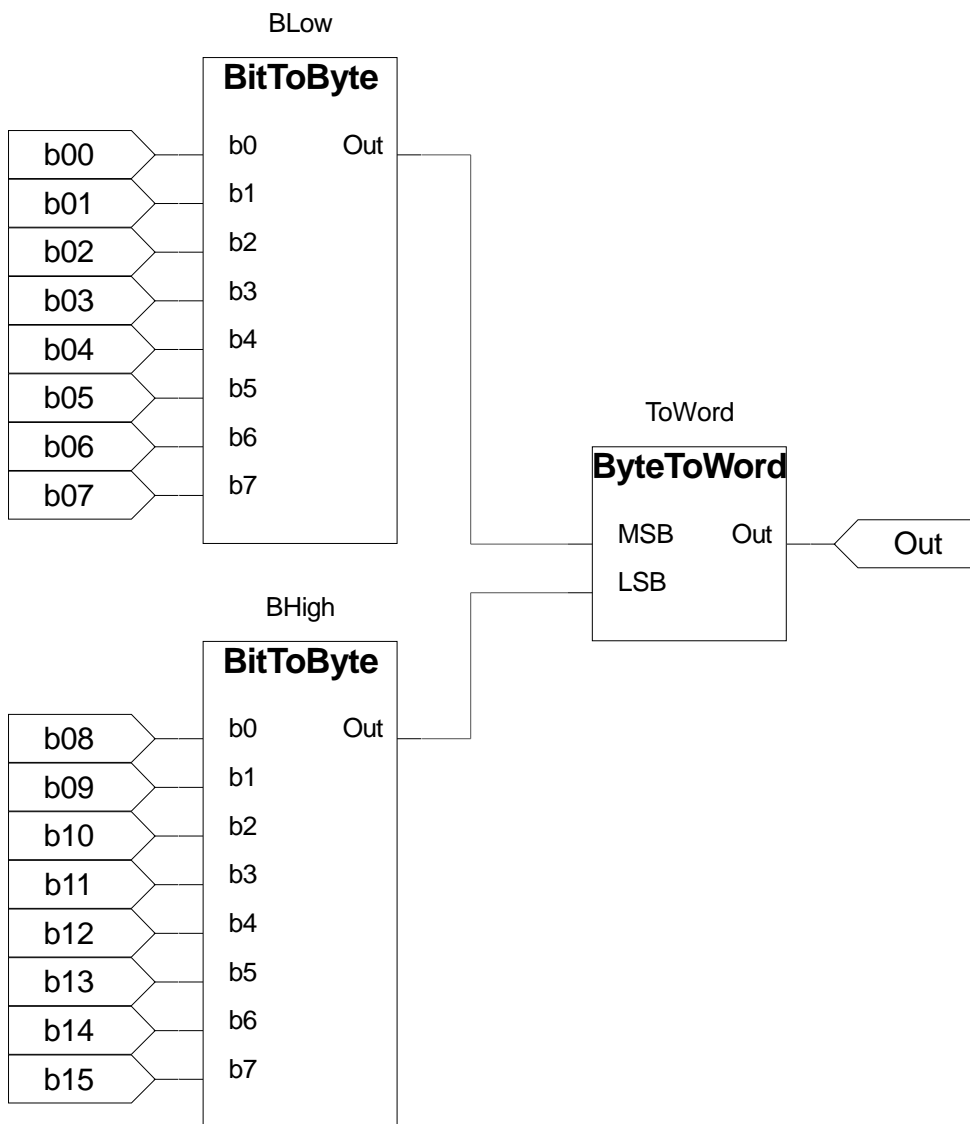

1

|  |                               |                 |
|--|-------------------------------|-----------------|
|  | Project : BitToWord           |                 |
|  | FUNCTION BLOCK : BitToWordFBD |                 |
|  | Release : NewFB               | Ver :1.00       |
|  | Author :                      | Date:20/11/2013 |
|  | Note :                        | Page:2 of 2     |

(SFR054B210) Merges 8 BOOL variables into a BYTE

```
VAR_INPUT
b00 : BOOL;
b01 : BOOL;
b02 : BOOL;
b03 : BOOL;
b04 : BOOL;
b05 : BOOL;
b06 : BOOL;
b07 : BOOL;
b08 : BOOL;
b09 : BOOL;
b10 : BOOL;
b11 : BOOL;
b12 : BOOL;
b13 : BOOL;
b14 : BOOL;
b15 : BOOL;
END_VAR
```

```
VAR_OUTPUT
Out : WORD; (* Function result *)
END_VAR
```

```
1 (* ***** *)
2 (* FUNCTION BLOCK "BitToWordST" *)
3 (* ***** *)
4 (* Il blocco funzione esegue la conversione di variabili bit in word. *)
5 (* ----- *)
6 (* Esego inizializzazione risultato. *)
7
8     Out:=0; (* Function result *)
9
10 (* Esego controllo stato di ogni bit. *)
11
12     IF (b00) THEN Out:=Out OR 16#0001; END_IF; (* Function result *)
13     IF (b01) THEN Out:=Out OR 16#0002; END_IF; (* Function result *)
14     IF (b02) THEN Out:=Out OR 16#0004; END_IF; (* Function result *)
15     IF (b03) THEN Out:=Out OR 16#0008; END_IF; (* Function result *)
16     IF (b04) THEN Out:=Out OR 16#0010; END_IF; (* Function result *)
17     IF (b05) THEN Out:=Out OR 16#0020; END_IF; (* Function result *)
18     IF (b06) THEN Out:=Out OR 16#0040; END_IF; (* Function result *)
19     IF (b07) THEN Out:=Out OR 16#0080; END_IF; (* Function result *)
20     IF (b08) THEN Out:=Out OR 16#0100; END_IF; (* Function result *)
21     IF (b09) THEN Out:=Out OR 16#0200; END_IF; (* Function result *)
22     IF (b10) THEN Out:=Out OR 16#0400; END_IF; (* Function result *)
23     IF (b11) THEN Out:=Out OR 16#0800; END_IF; (* Function result *)
24     IF (b12) THEN Out:=Out OR 16#1000; END_IF; (* Function result *)
25     IF (b13) THEN Out:=Out OR 16#2000; END_IF; (* Function result *)
26     IF (b14) THEN Out:=Out OR 16#4000; END_IF; (* Function result *)
27     IF (b15) THEN Out:=Out OR 16#8000; END_IF; (* Function result *)
28
29 (* [End of file] *)
30
31
```

|                              |                 |
|------------------------------|-----------------|
| Project : BitToWord          |                 |
| FUNCTION_BLOCK : BitToWordST |                 |
| Release : NewFB              | Ver :1.00       |
| Author :                     | Date:20/11/2013 |
| Note :                       | Page:1 of 1     |

FUNCTION\_BLOCK BitToByte

(SFR054B210) Merges 8 BOOL variables into a BYTE  
ENCRYPTED CODE

VAR\_INPUT

b0 : BOOL;

b1 : BOOL;

b2 : BOOL;

b3 : BOOL;

b4 : BOOL;

b5 : BOOL;

b6 : BOOL;

b7 : BOOL;

END\_VAR

VAR\_OUTPUT

Out : BYTE; (\* Function result \*)

END\_VAR

1

|  |                            |                 |
|--|----------------------------|-----------------|
|  | Project : BitToWord        |                 |
|  | FUNCTION BLOCK : BitToByte |                 |
|  | Release : NewFB            | Ver :1.00       |
|  | Author :                   | Date:20/11/2013 |
|  | Note :                     | Page:1 of 1     |

FUNCTION\_BLOCK ByteToWorld

(SFR054B210) Merges 2 BYTE variables into a WORD  
ENCRYPTED CODE

```
VAR_INPUT
MSB : BYTE; (* MSB Value *)
LSB : BYTE; (* LSB Value *)
END_VAR

VAR_OUTPUT
Out : WORD; (* Function result *)
END_VAR
```

1

|  |                              |                 |
|--|------------------------------|-----------------|
|  | Project : BitToWorld         |                 |
|  | FUNCTION BLOCK : ByteToWorld |                 |
|  | Release : NewFB              | Ver :1.00       |
|  | Author :                     | Date:20/11/2013 |
|  | Note :                       | Page:1 of 1     |